

GREE DUCTFREE MINI-SPLITS OUTDOOR CONDENSING UNITS
PAD MOUNT CONFIGURATION AND ANCHOR SELECTION - WIND LOAD EXAMINATION

CODE: FMC and FBC 7th Ed. (2020) BLDG, ASCE 7-16
MIAMI-DADE WIND SPEED = 195 MPH (Risk Cat. IV)

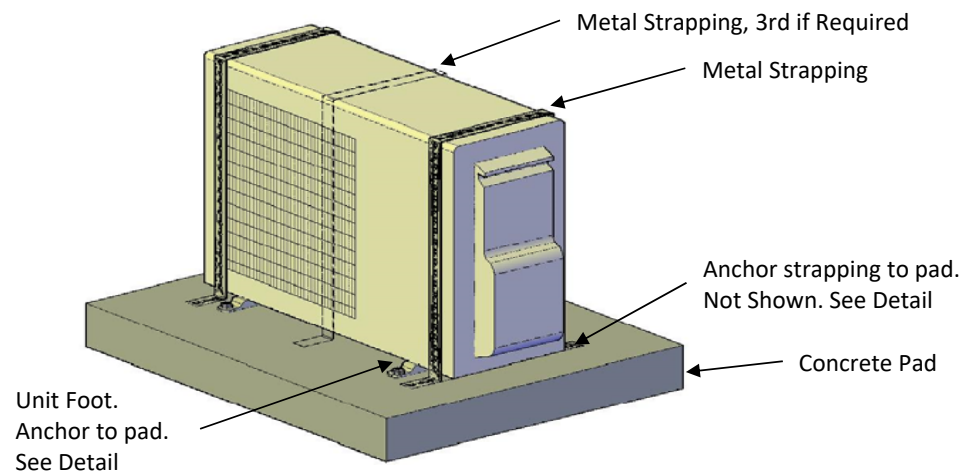

ENGINEERING CONFORMANCE ANALYSIS:

THE TABLE SHOWS PAD SIZE AND ANCHOR TYPES FOR VARIOUS MODELS OF HVAC OUTDOOR EQUIPMENT UP TO 4 TONS THAT MEET THE FOLLOWING ANALYSIS: • OVERTURN • EDGE CLEARANCES • ANCHOR PULLOUT AND SHEAR STRENGTH • EQUIPMENT INTEGRITY.

TABLE A-2

UMAT GEN3 - Series		Weight	Length	Width B	Height	Mount	Mount
Model No.		(lbs)	C (in.)	(in.)	A (in.)	E (in.)	F (in.)
UMAT18HP230V1AO/BO		106	35.1	13.4	27.6	14.2	22.0
UMAT24HP230V1AO/BO		152	36.2	14.6	31.1	15.6	24.0
UMAT30HP230V1AO/BO		159	36.2	14.6	31.1	15.6	24.0
UMAT36HP230V1AO/BO		205	40.0	14.2	43.5	15.7	24.8
UMAT42HP230V1AO/BO		210	35.4	13.4	45.3	14.8	22.4
UMAT48HP230V1AO/BO		232	35.4	13.4	45.3	14.8	22.4

Installation Requirements				
Anchor Type	Pad Size, minimum (in.)			# of Straps If Required
	W	D	t	
A-1	46	44	4	Yes, 2
A-1	48	48	4	Yes, 2
A-1	48	48	4	Yes, 2
A-2	52	52	6	Yes, 3
A-2	52	52	6	Yes, 3
A-2	52	52	6	Yes, 3

Design Check: Nomnal / Reqd ≥ 1.00 = OK		
Overturn	Anchor Pullout	Anchor Sliding
1.06	2.12	3.02
1.03	1.83	2.60
1.04	1.83	2.60
1.03	1.25	3.08
1.11	1.25	3.34
1.13	1.26	3.34

Bri-Ko Engineering, Inc., Spreadsheet designed by: B. Schwartz, PE
Structural Analysis Date data input: 25-Mar-21

Calc Sht: EC-1 Mechanical Equipment on Concrete Pad Calc
Description: Structural Analysis of concrete pad mounted mechanical equipment to resist wind forces.

Code: FBC 7th Ed. (2020) and ASCE 7-16.

Design Methodology and Load Combinations:

Design Method: LRFD $\Phi = 0.90$
Load Combos: FBC Eqn. 16-6 0.9 D + 1.0 W

Wind Forces: based on FBC Section 1620 (equipment is stand-alone structure.)

Ultimate Design Wind Speed, Vult (3-sec gust): **195 mph** Miami Dade
Nominal Design Wind Speed, Vasd: 151 mph
Risk Category: **IV** Dir., Topo., Gust Effect: 0.90 1.00 N/A
Height, h: 15 ft Exp. Cat.: **C** Vel. Pres. Exp Coef., Kz: 0.849

Velocity Pressure $q_h = 0.00256 K_z K_{zt} K_d V^2$ (lb/ft²) $q_h = 74.4$ psf
 $F = q_h(GCr)Af$ (GC_r)_{v,l} = (1.0 ver., 1.1 lat.) F_{ver, Flat}: **74.4 psf, 81.8 psf**

Limit States:

Select UnitType: UMAT
Select model # for illustration purposes: UMAT48HP230V1AO/BO

Verify Pad and anchor clearances:

Anchor critical edge distance is $12d = 4.5"$ for 0.375" dia.
Distance from pad edge to AC unit = 8.3 in. **CHECKS OK**
Dist from pad edge to anchor center = 14.8 in. **CHECKS OK**

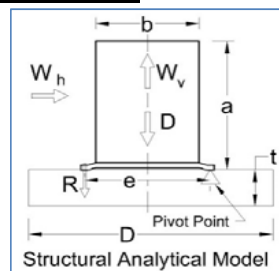

Resistance to Pad overturn: Use Load Combo: 0.67 D + 0.78 W FBC 1605.3.2 Eqn. 16-18
Concrete Pad wt: 1408 lbs Overturn moment due to wind = 25.3 k-in
Counter moment due to dead weight = 28.6 k-in **Checks OK**

Resistance to sliding: Use Load Combo: 0.90 D + 1.00 W FBC 1605.2 Eqn. 16-6
Reqd Shear = $1.00 * (P_{wh} * Area) = 911$ lbs
Nominal Shear from Table A-1 * 4 anchors = 3040 lbs **Checks OK**

Anchor hold down: Use Load Combo: 0.67 D + 0.78 W FBC 1605.3.2 Eqn. 16-18
Required overturn moment about unit edge = 16.4 k-in
Nominal Anchor pull-down from Table A-1 * E * 2 anchors = 20.6 k-in **Checks OK**

Unit Integrity: If Required. Only if manufacturer does not state design wind pressure.

Required tension on strap = 519 lbs
Strap width, gauge = 1.375 in. 22ga min gauge thickness
Steel Strength = 36 ksi min. Strength of strap = 654 lbs **Checks OK**

Input Criteria:	
Concrete Pad weight:	150 pcf
Pad edge to anch distance (min):	4.5 in.
Pad edge to AC unit (min):	2.0 in.

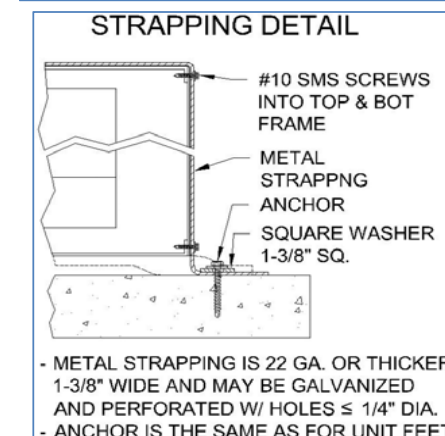
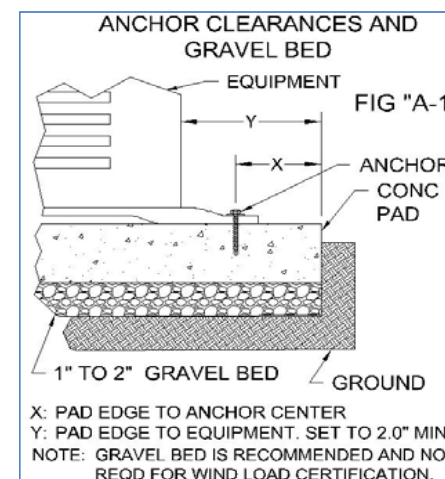
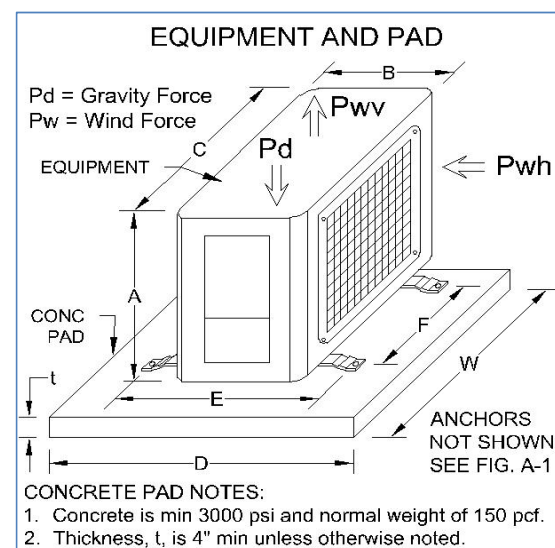

- Must have pad oriented with long side perpendicular to width of unit.
- Anchor Type is the minimum, higher strength types permitted.

GENERAL NOTES:

- THIS ENGINEERING REPORT DOCUMENTS THE ANALYSIS OF THE PERFORMANCE OF HVAC MECHANICAL EQUIPMENT TO MEET WIND LOAD OVERTURN AND ANCHOR STRENGTH.
- THE ANALYSIS CONFORMS TO THE REQUIREMENTS OF THE FBC 7th ed. (HIGH VELOCITY HURRICANE ZONE) AND ASCE 7-16 DESIGN WIND LOADS - OTHER STRUCTURES SECTION 29.5. NOTE: THE CONCRETE PAD AND AC UNIT IS NOT A ROOFTOP STRUCTURE.
- THE LOAD PATH VERIFIED IS FROM THE EQUIPMENT AS A SINGLE UNIT, UNIT LEG ANCHORS TO CONC SLAB.
- PADS ARE EITHER POURED IN PLACE OR PRE-FABRICATED NORMAL WEIGHT CONCRETE WITH A MINIMUM STRENGTH OF 3000 PSI AND ARE LOCATED AT GROUND LEVEL.
- ANCHORS USED TO FASTEN THE CONDENSER FEET TO THE CONCRETE PAD ARE DEFINED IN TABLE A-1 AND SPECIFIED IN TABLE A-2. THE EMBED IS SPECIFIED IN TABLE A-1. THESE ANCHORS ARE TYPICALLY MANUFACTURED FROM HEAT-TREATED STEEL AND HAVE CORROSION RESISTANCE AS SPECIFIED BY THE MANUFACTURER.
- AC UNIT MUST BE CENTERED ON PAD WITH OPPOSITE SIDES HAVING EQUAL CLEARANCE.
- UNIT INTEGRITY, IF NOT DESIGNATED BY THE MANUFACTURER FOR THE STATED WIND PRESSURES, IS MET BY STRAPPING THE UNIT DIRECTLY TO THE PAD.

CALCULATIONS:

- OVERTURN:**
1. THE CRITICAL WIND LOAD IS ON THE LONG FACE OF THE CONDENSER. THE MOMENT CREATED BY THE WIND LOAD MUST BE RESISTED BY THE MOMENT CREATED FROM THE WEIGHT OF THE PAD AND THE CONDENSER.
- CLEARANCES:**
2. DISTANCE FROM THE EDGE OF THE PAD TO THE CONDENSER SIDE (Y IN FIG.) MUST BE GREATER THAN 2.0 INCH. DISTANCE FROM THE EDGE OF THE PAD TO THE CENTER OF THE ANCHOR MUST BE GREATER THAN THAT SPECIFIED IN THE INPUT CRITERIA.
- ANCHOR STRENGTH:**
3. THE SLIDING RESISTANCE IS TRANSFERRED TO THE PAD BY THE SHEAR STRENGTH IN THE ANCHORS. THE OVERTURN RESISTANCE IS TRANSFERRED TO THE PAD BY THE ANCHORS. CONFIGURATION AND ANCHOR STRENGTH BASED ON MINIMUM EDGE DISTANCE YIELD MOMENT RESISTANCE.
- UNIT INTEGRITY:**
4. IF REQUIRED, STRAPPING ATTACHED TO THE UNIT AND ANCHORED TO THE PAD RESISTS SHELL AND FRAME SEPARATION.

TABLE A-1 ANCHOR TYPE AND ALLOWABLE STRENGTHS				
SYM	ANCHOR DESCRIPTION & MANUFACTURER	EMBED	STRENGTH AT MIN EDGE DISTANCE	
			PULL OUT (LBS)	SHEAR (LBS)
A-1	1/4" TAPCON (Buildex)	1-3/4"	505	415
A-2	5/16" Hvy Duty Tapcon (Buildex)	1-3/4"	695	760
A-3	3/8" WEDGE BOLT (Powers)	2-1/2"	1025	1370

Notes: 1. Allowable strengths have safety factor of 4 are for poured concrete min 3000 psi from manufacturer's specs.
2. Each anchor includes a 1"Ø fender washer.

Sheet: ENG-1	BRI-KO ENGINEERING INC	Cert. Of Auth.: #27622	tel: 954.648.6218
Doc: Page 1 of 1	This item has been digitally signed and sealed by Brian I Schwartz on the date adjacent to the seal. Printed copies of this document are not considered signed and sealed and the signature must be verified on any electronic copies.		
Gree -UMAT GEN3_ConcPad			
Issue Date: 25-Mar-21			
Dwn By: B.S.			
Dwg Size: 11x 17			